

TOGE TSO Suspension Spring Anchor

Approved for use in cracked and uncracked concrete
(For multiple use in non-structural applications)



NEW



TOGE TSO

Suspension Spring Anchor



- Carbon Steel Zinc Clear
- Easily installs by hand



ETA – 11 / 0290



Part No.	Description	mm	mm	qty	qty
TSO06040	6 x 40 suspension spring anchor	6	10	100	n/a

Technical Information

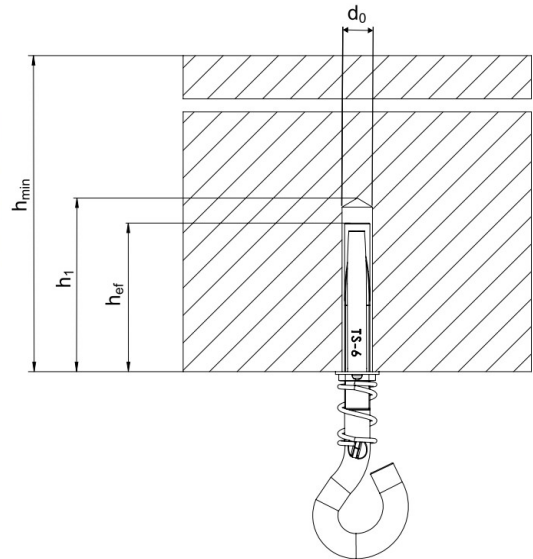
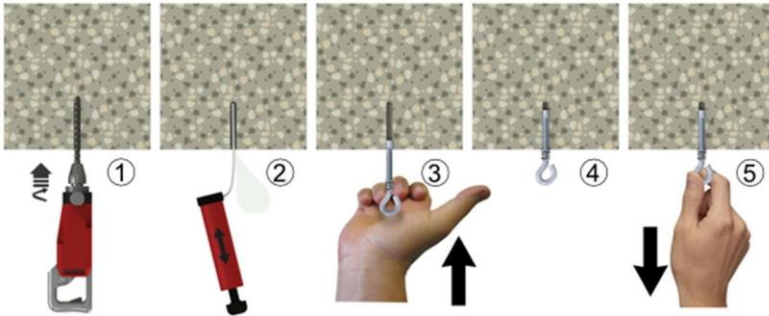

Technical Specifications			
			TOGE TSO
Part No.			TSO06040
Drill diameter	d_0	[mm]	6
Hole depth	$h_1 \geq$	[mm]	40
Anchorage depth	$h_{ef} \geq$	[mm]	33
Minimum thickness	h_{min}	[mm]	80
Minimum edge distance	c_{min}	[mm]	100
Minimum spacing	s_{min}	[mm]	200
Allowable load in concrete C 20/25 to C 50/60	F_{Rd}	[kN]	0,7

ICCONS Pty Ltd.

Head Office, 12-18 Produce Drive,
Dandenong South, Victoria, 3175

P: 03 9706 4344

F: 03 9768 3329

E: info@iccons.com.au